

Numerical modeling of a test assessing the tensile strength of Steel Fiber Reinforced Concrete

Alba Pros^{1,2}, Climent Molins², and Pedro Díez¹

¹ Laboratori de Càlcul Numèric
Departament de Matemàtica Aplicada III
Universitat Politècnica de Catalunya
Campus Nord UPC, 08034 Barcelona, Spain

² Departament d'Enginyeria de la Construcció
Universitat Politècnica de Catalunya
Campus Nord UPC, 08034 Barcelona, Spain

Key Words: *Steel Fiber Reinforced Concrete, Numerical modeling, Validation, Finite Element Method, Immersed boundary Method.*

ABSTRACT

Steel Fiber Reinforced Concrete (SFRC) is a promising technology that allows the tensile strength of the concrete to increase with a lower manufacturing cost, with respect to the standard reinforced concrete.

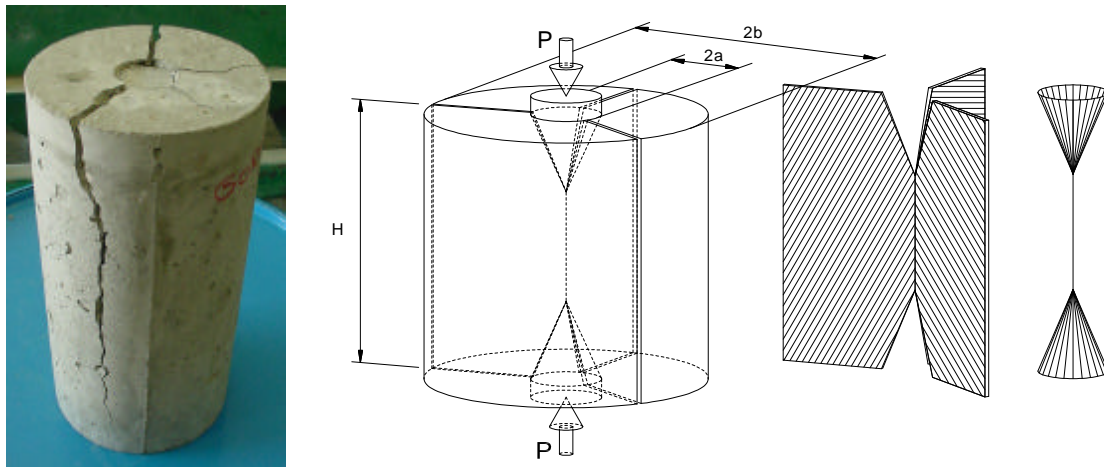

Figure 1: *Description of the BCN Test. The cylindrical (15 cm diameter, 15 cm height) sample is compressed by two steel punches (cylinders of diameter 3.75 cm)*

The behavior of the SFRC under shear and normal stresses is properly characterized by several experimental tests. The so-called Barcelona Test (BCN Test) [1,2], see Figure 1, is an adaptation of the Double Punch Test for SFRC and it is found to provide a fair characterization of the tensile response of the material [3]. In fact, the test consists on a displacement controlled compression of the sample,

allows to use samples of small sizes and produces results (indirect measures of the tensile strength) with a reduced scattering.

A extensive experimental campaign has been carried out and a large set of experimental results characterizing the behavior of the BCN Test is available. The numerical modeling is targeted to reproduce the main features of these experimental results. The outcome of the experiments are force-displacement curves (displacement driven tests with constant speed). The validation of the numerical model is therefore performed on the basis of this outcome, and the quality of the numerical model is measured comparing the numerical and the experimental curves.

First, the constitutive model is validated for plain concrete, without any reinforcement. Following [4], the concrete is modeled using a nonlocal Mazars damage model. The material parameters for the plain concrete are fitted using the experimental results for non-reinforced samples.

The complete simulation of the SFRC requires accounting for the steel fibers (wires) distributed in the concrete bulk. Two alternatives are considered: 1) the fibers are discretized using 1D beam elements that coincide with the edges of Finite element mesh of the concrete bulk and 2) the fibers are introduced independently of the bulk mesh by using the ideas introduced for the Immersed Boundary (IB) methods. The first approach is straightforwardly implemented in a standard FE code but requires a huge pre-processing effort to obtain the complying mesh. The second alternative is more flexible because allows performing independent discretizations for the concrete bulk and the fibers. The IB method has been introduced in the context of fluid-structure interaction [5,6]. The influence of the structure in the fluid is accounted for using concentrated masses and forces. Here, the concrete bulk plays the role of the fluid and the steel fibers play the role of the immersed structure. The information transfer is in this case much easier than in the fluid because of the Lagrangian description of the bulk.

REFERENCES

- [1] C. Molins, A. Aguado, S. Saludes, T. García. "New test to control tension properties of FRC". Proceedings of the *EURO:TUN 2007 ECCOMAS Thematic Conference on Computational Methods in Tunnelling*, J. Eberhardsteiner et.al. Eds., Viena 2007
- [2] C. Molins, A. Aguado, A. Marí. "Quality Control test for SFRC to be used in precast segment". *Tunnelling and Underground Space Technology*, Vol. **21**, 423-424.
- [3] K. T. Chau, X. X. Wei. "Finite solid circular cylinders subjected to arbitrary surface load". *International Journal of Solids and Structures.*, Vol. **37**, 5707-5744, 2000.
- [4] A. Rodríguez-Ferran, A. Huerta. "Error estimation and adaptivity for nonlocal damage models". *International Journal of Solids and Structures.*, Vol. **37**, 7501-7528, 2000.
- [5] D. Boffi, L. Gastaldi. "A finite element approach of the immersed boundary method". *Computers and Structures.*, Vol. **81**, 491-501, 2003.
- [6] R. Mittal, G. Iaccarino. "Immersed boundary methods". *Annu. Rev. Fluid. Mech.*, Vol. **37**, 239-261, 2005.